



333 Bayview Avenue
Amityville, New York 11701
For Sales and Repairs, (800) 645-9445
For Technical Service, (800) 645-9440
Publicly traded on NASDAQ Symbol: NSSC

© NAPCO 2006

NAPCO NetLink™ NL-ULBD

Transient Protection Device

INSTALLATION INSTRUCTIONS

WI1256A 6/06

GENERAL DESCRIPTION

The NAPCO NetLink™ NL-MOD is a device that allows the reporting of alarms over a TCP/IP based (Intranet or Internet) network. The NL-MOD is housed in a separate plastic enclosure, and although it includes electromagnetic protection (and meets direct and indirect ESD requirements for Information Technology equipment), burglary applications may call for better protection.

Therefore, the NL-ULBD was created to provide added transient protection and mounts entirely inside the NL-MOD housing. The NL-ULBD protects the NL-MOD from significantly larger transients and surges which may emanate from the network cable or associated devices. It is connected in series between the Ethernet cable that provides network access and the RJ45 connector in the NL-MOD.

Note: For NL-MOD installation instructions, please see WI1242. Before installing the NL-ULBD, be sure to remove power to the panel, and that the installation of the NL-MOD is complete as per the WI1242 instructions.

1. **Install the NL-ULBD.** Within the NL-MOD housing, install the NL-ULBD using the self-tapping screw (supplied). Place the screw through the E2 mounting hole in the NL-ULBD and into the upper-right corner mounting hole until secure.
2. **Connect Earth Ground.** Connect a ground wire to NL-ULBD terminal 2 (marked "Connect to Earth Ground"), and

connect the other end to the *Earth Ground* mounting screw located on the control panel board (or to the same ground location to which that panel *Earth Ground* mounting screw is connected). Wind wire through vertical slats in housing (see illustration below). Be sure to use a No. 18 AWG. or larger wire to a metal cold-water pipe. Do not use a gas pipe, plastic pipe or AC ground connections. **NOTE:** Grounding connections should avoid bends in the grounding wire whenever possible.

3. **Control Panel Connections.** Connect the NL-MOD to the control panel as described in WI1242.
4. **Network Connection.** Connect the NL-ULBD to the network by connecting the network RJ45 cable into the NL-ULBD receptacle marked "To Network".
5. **Connect Patch Cable.** Connect the CAT5e patch cable (1 foot in length, supplied) into the NL-MOD RJ45 receptacle marked "Ethernet" and connect the other end into the NL-ULBD receptacle marked "To NL-MOD Ethernet Input".
Important: DO NOT crimp or bend cable. Cable must maintain a wide radius to ensure high speed data transfer. See image below.

After all connections are complete, apply power to the NL-MOD as described in WI1242.

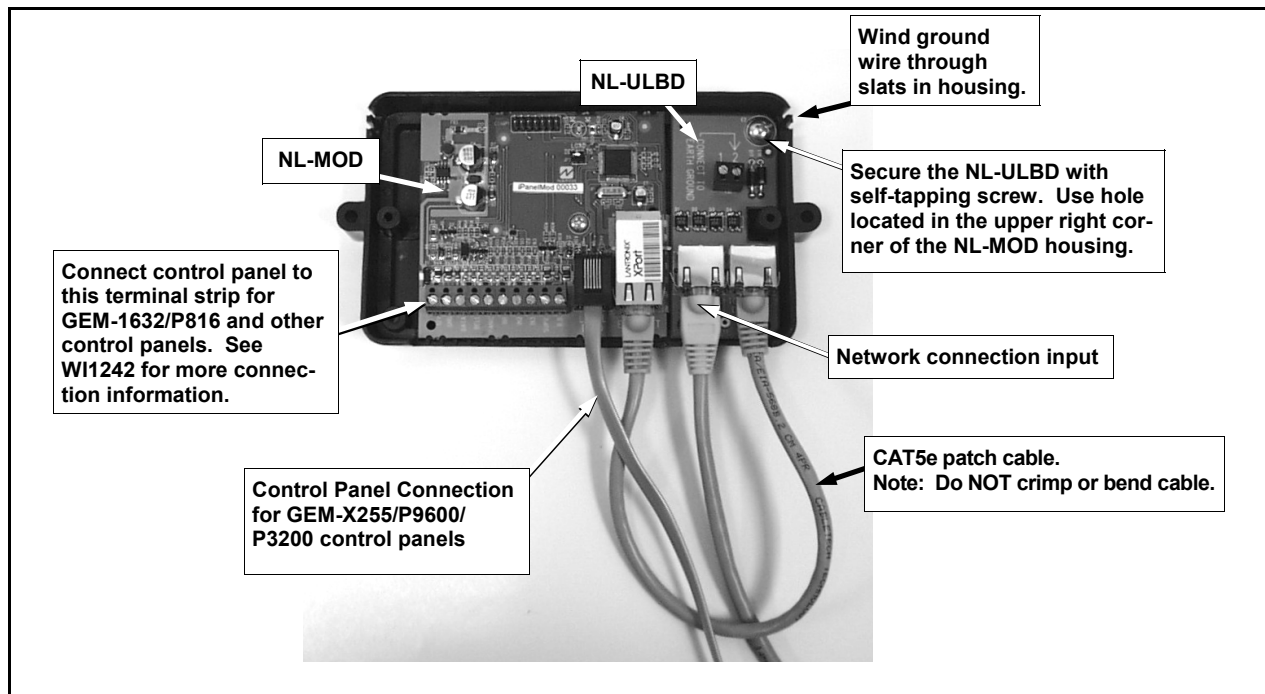

NAPCO LIMITED WARRANTY

NAPCO SECURITY SYSTEMS, INC. (NAPCO) warrants its products to be free from manufacturing defects in materials and workmanship for thirty-six months following the date of manufacture. NAPCO will, within said period, at its option, repair or replace any product failing to operate correctly without charge to the original purchaser or user.

This warranty shall not apply to any equipment, or any part thereof, which has been repaired by others, improperly installed, improperly used, abused, altered, damaged, subjected to acts of God, or on which any serial numbers have been altered, defaced or removed. Seller will not be responsible for any dismantling or reinstallation charges.

THERE ARE NO WARRANTIES, EXPRESS OR IMPLIED, WHICH EXTEND BEYOND THE DESCRIPTION ON THE FACE HEREOF. THERE IS NO EXPRESS OR IMPLIED WARRANTY OF MERCHANTABILITY OR A WARRANTY OF FITNESS FOR A PARTICULAR PURPOSE. ADDITIONALLY, THIS WARRANTY IS IN LIEU OF ALL OTHER OBLIGATIONS OR LIABILITIES ON THE PART OF NAPCO.

Any action for breach of warranty, including but not limited to any implied warranty of merchantability, must be brought within the six months following the end of the warranty period.

IN NO CASE SHALL NAPCO BE LIABLE TO ANYONE FOR ANY CONSEQUENTIAL OR INCIDENTAL DAMAGES FOR BREACH OF THIS OR ANY OTHER WARRANTY, EXPRESS OR IMPLIED, EVEN IF THE LOSS OR DAMAGE IS CAUSED BY THE SELLER'S OWN NEGLIGENCE OR FAULT.

In case of defect, contact the security professional who installed and maintains your security system. In order to exercise the warranty, the product must be returned by the security professional, shipping costs prepaid and insured to NAPCO. After repair or replacement, NAPCO assumes the cost of returning products under warranty. NAPCO shall have no obligation under this warranty, or otherwise, if the product has been repaired by others, improperly installed, improperly used, abused, altered, damaged, subjected to accident, nuisance, flood, fire or acts of God, or on which any serial numbers have been altered, defaced or removed. NAPCO will not be responsible for any dismantling, reassembly or reinstallation charges.

This warranty contains the entire warranty. It is the sole warranty and any prior agreements or representations, whether oral or written, are either merged herein or are expressly canceled. NAPCO

neither assumes, nor authorizes any other person purporting to act on its behalf to modify, to change, or to assume for it, any other warranty or liability concerning its products.

In no event shall NAPCO be liable for an amount in excess of NAPCO's original selling price of the product, for any loss or damage, whether direct, indirect, incidental, consequential, or otherwise arising out of any failure of the product. Seller's warranty, as hereinabove set forth, shall not be enlarged, diminished or affected by and no obligation or liability shall arise or grow out of Seller's rendering of technical advice or service in connection with Buyer's order of the goods furnished hereunder.

NAPCO RECOMMENDS THAT THE ENTIRE SYSTEM BE COMPLETELY TESTED WEEKLY.

Warning: Despite frequent testing, and due to, but not limited to, any or all of the following: criminal tampering, electrical or communications disruption, it is possible for the system to fail to perform as expected. NAPCO does not represent that the product/system may not be compromised or circumvented; or that the product or system will prevent any personal injury or property loss by burglary, robbery, fire or otherwise; nor that the product or system will in all cases provide adequate warning or protection. A properly installed and maintained alarm may only reduce risk of burglary, robbery, fire or otherwise but it is not insurance or a guarantee that these events will not occur. CONSEQUENTLY, SELLER SHALL HAVE NO LIABILITY FOR ANY PERSONAL INJURY, PROPERTY DAMAGE, OR OTHER LOSS BASED ON A CLAIM THE PRODUCT FAILED TO GIVE WARNING. Therefore, the installer should in turn advise the consumer to take any and all precautions for his or her safety including, but not limited to, fleeing the premises and calling police or fire department, in order to mitigate the possibilities of harm and/or damage.

NAPCO is not an insurer of either the property or safety of the user's family or employees, and limits its liability for any loss or damage including incidental or consequential damages to NAPCO's original selling price of the product regardless of the cause of such loss or damage.

Some states do not allow limitations on how long an implied warranty lasts or do not allow the exclusion or limitation of incidental or consequential damages, or differentiate in their treatment of limitations of liability for ordinary or gross negligence, so the above limitations or exclusions may not apply to you. This Warranty gives you specific legal rights and you may also have other rights which vary from state to state.